



***X25ELM* APPLICATION**

USER'S MANUAL



BUILD 1.X

102 SW Orange Blossom
Lake City, Florida
32025-1613
phone: 386-754-5700
email: sales@trdcusa.com
<http://www.trdcusa.com>

CONTENTS

1. INTRODUCTION..... 4

2. CONFIGURATION..... 5

3. TCP PORTS 7

4. X25ELM REQUIRED CONFIGURATION 8

5. APPLICATIONS COMMANDS 9

5.1 INPUT CONVENTIONS..... 9

5.2 LOGIN..... 9

5.3 LOGOUT..... 9

5.4 CHANGE PASSWORD..... 10

5.5 HELP..... 10

5.6 VERSION..... 10

5.7 PLACING COMPONENTS IN SERVICE 10

5.8 TAKING COMPONENTS OUT OF SERVICE 11

5.9 CONFIGURING GENERAL & SLM PARAMETERS 11

5.10 VIRTUAL CIRCUIT CONFIGURATION..... 12

5.11 DISPLAY MEASUREMENTS..... 14

5.12 VERIFY CONFIGURATION..... 14

5.13 DISPLAYING CURRENT CONNECTIONS..... 14

5.14 SNOOPING TRAFFIC 14

5.15 PROMPT LABELS..... 15

5.16 APPLICATION COMMENTS 15

5.17 CLOSED USER GROUPS..... 15

5.18 CONSOLE SECURITY 16

6. X25ELM MEASUREMENTS AVAILABLE 17

7. SUPPORT FOR X.3 PAD PARAMETER VALUES..... 18

8. X25ELM SAMPLE DEPLOYMENT 21

9. END-USER LICENSE AGREEMENT FOR SOFTWARE 24

SOFTWARE LICENSE 24

INTELLECTUAL PROPERTY RIGHTS 24

SOFTWARE SUPPORT 24

EXPORT RESTRICTIONS..... 24

LIMITED WARRANTY..... 24

NO OTHER WARRANTIES..... 25

LIMITATION OF LIABILITY 25

SPECIAL PROVISIONS..... 25

10. SALES & DISTRIBUTION..... 26

11. AUTHOR..... 26

1. INTRODUCTION

The X25ELM Application is used to provide a feature rich pad interface to the Switching Control (SCC) links of network elements (NE). Network surveillance links, which are simplex, may also be accessed using the X25ELM.

The SCC links of a network element are grouped in pairs of BX.25 links where only one link may be active at any one time. The co-ordination between links has been traditionally done with the Operations System and the IP-SLM mediation interface application. The IP-SLM application is the official standard for interface to #5ESS and other Lucent Technologies Network Elements and Operations systems. It can interface to any of the BX.25 based network elements. A full description of the IP-SLM mediation interface may be found in it's user manual.

The BX.25 interfaces used for network elements are unique, and the X25ELM does not attempt to interface to them directly. Instead, the X25ELM replaces the Operations System functionality of link control and interfaces to up to two copies of the IP-SLM application. A diagram of the deployment is as follows:

SCC Circuits - Diverse Redundant Routing

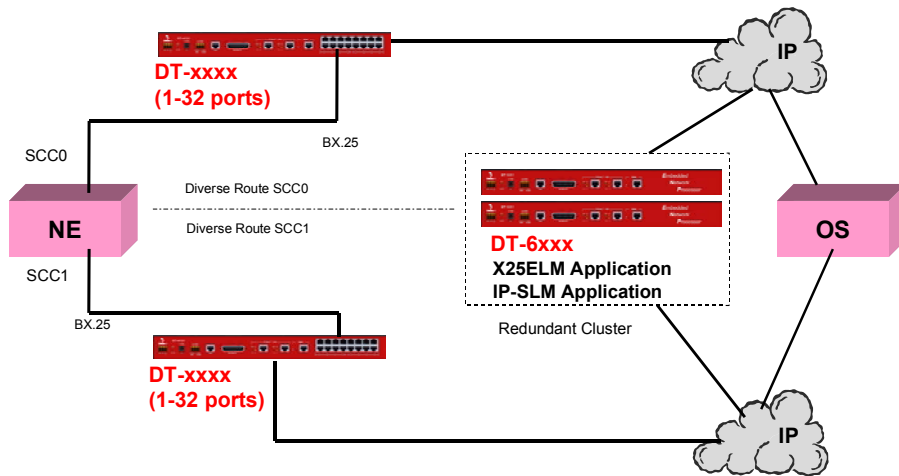

In the diagram above, the X25ELM and IP-SLM are resident on the same application processor. That particular configuration is not required. However, SCC interfaces should be redundant and diverse.

For TDMS circuits, the configuration may be deployed without redundancy as those connections are simplex.

The interface presented to the Operations System is a configurable PAD including binary options and packet preservation such as the RBP protocol.

By using the industry standard IP-SLM application, the proper management of the idiosyncracies of the network element BX.25 links are assured. The X25ELM automatically switches links on a failure, and also provides manual commands to affect the same result.

2. CONFIGURATION

Each DT-xxxx may simultaneously run numerous instances of one or several applications concurrently. The DT-6061 and DT-6160 each support 30 instances. The DT-6260 supports 48 instances. The X25ELM application has been engineered specifically for the DT-6160.

Support for a single NE with diverse SCC BX.25 links requires a total of 3 instances. One for the X25ELM, and one each for the IP-SLM associated with the BX.25 link. The instances do not need to be on the same DT-6xxx; but it is highly recommended. The DT-6xxx should be paired in a redundant cluster for fault tolerance.

The X25ELM application is operable on instances one through ten inclusive on the DT-6061 and DT-6160. The X25ELM application is operable on instances one through sixteen inclusive on the DT-6260. The remaining instances on each device are for the IP-SLM application instances.

The following diagram shows the connectivity between the components:

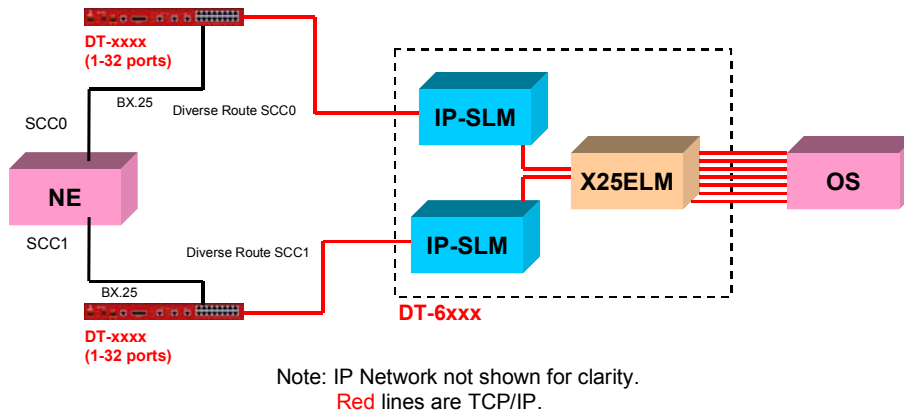

In the diagram above, the IP network connections are not shown for clarity. The **RED** interfaces are all TCP/IP, may traverse a network of any size, and need not be co-located.

Each NE has one to seven active BX.25 VCs on the active link. Each of these active BX.25 VCs becomes a TCP/IP connection to the operations system. The formatting of the data on the interfaces is configurable on the X25ELM on a per VC basis. A fault-over of the BX.25 link does not affect the TCP/IP connections on a per BX.25 VC basis between the X25ELM and the Operations System.

The X25ELM has connections to each IP-SLM and performs the line control functions typically done by the operations system. The protocol on these interfaces is the industry standard SLM protocol carried over TCP/IP. Configuration of the SCC BX.25 link is done by the IP-SLM.

Each IP-SLM has a connection to a SCC network connection via a DT-xxxx interface. Any of the DT-xxxx devices may be used. A Datakit/BNS endpoint, such as a SAM64 port, may also be used via a Universal Mediation Interface module.

The assignment of the application instances in the DT-6160 is in groups of three:

NE #1	X25ELM (#1)	IP-SLM (#11)	IP-SLM (#21)
NE #2	X25ELM (#2)	IP-SLM (#12)	IP-SLM (#22)
NE #3	X25ELM (#3)	IP-SLM (#13)	IP-SLM (#23)
NE #4	X25ELM (#4)	IP-SLM (#14)	IP-SLM (#24)
NE #5	X25ELM (#5)	IP-SLM (#15)	IP-SLM (#25)
NE #6	X25ELM (#6)	IP-SLM (#16)	IP-SLM (#26)
NE #7	X25ELM (#7)	IP-SLM (#17)	IP-SLM (#27)
NE #8	X25ELM (#8)	IP-SLM (#18)	IP-SLM (#28)
NE #9	X25ELM (#9)	IP-SLM (#19)	IP-SLM (#29)
NE #10	X25ELM (#10)	IP-SLM (#20)	IP-SLM (#30)

3. TCP PORTS

The OS makes a TCP connection to the X25ELM on a per Virtual Circuit basis. There are several TCP ports available on each X25ELM instance. These are at $30000 + (200 * (\text{instance} - 1)) + \text{VC\#}$.

For example, for instance #1, the 7 SCC VCs are at TCP port 30001 through 30007 inclusive. For instance #2, they are 30201 through 30207 inclusive. This is the standard numbering scheme for most DT-6xxx applications.

Each instance of the X25ELM has an OA&M TCP port. This exists at TCP $(10000 + \text{instance\#})$. For example, instance #1 is at TCP 10001. Instance #2 is at 10002, and so on.

The table below depicts the TCP ports used externally in a X25ELM system deployment. The “attach” TCP ports are used by the NE DT-xxxx interfaces. The “VC TCP ports” are used by the operations system. The Administrative interfaces exist for configuration and troubleshooting purposes only. Under normal circumstances, the X25ELM system uses the default configuration and access to the administrative interfaces is not required.

<u>NE</u>	<u>VC TCP Ports</u>	<u>X25ELM Admin</u>	<u>SCC0 IP-SLM Admin</u>	<u>SCC0 IP-SLM Attach</u>	<u>SCC1 IP-SLM Admin</u>	<u>SCC1 IP-SLM Attach</u>
#1	30001 - 30007	10001	10011	32000	10021	34000
#2	30201 - 30207	10002	10012	32200	10022	34200
#3	30401 - 30407	10003	10013	32400	10023	34400
#4	30601 - 30607	10004	10014	32600	10024	34600
#5	30801 - 30807	10005	10015	32800	10025	34800
#6	31001 - 31007	10006	10016	33000	10026	35000
#7	31201 - 31207	10007	10017	33200	10027	35200
#8	31401 - 31407	10008	10018	33400	10028	35400
#9	31601 - 31607	10009	10019	33600	10029	35600
#10	31801 - 31807	10010	10020	33800	10030	35800

4. X25ELM REQUIRED CONFIGURATION

The X25ELM defaults the PAD parameters to common values associated with the TL1 protocol. If these are sufficient, then no further configuration is needed.

The X25ELM has a default instance configuration per the table in the previous paragraph. The IP-SLM instances associated with the X25ELM must be active. The X25ELM makes a TCP/IP connection to these IP-SLM instances.

The X25ELM application does provide an over-ride configuration should the IP-SLM be desired in a remote location. If such is the case, the X25ELM is configured with the IP address and TCP port number of the resultant IP-SLM interface. The TCP port number is used in lieu of an instance number so that the connection may be indirected by another network. An example of such is being transported part of the way via a Datakit/BNS network via UMI modules. Other network examples are possible.

If the IP-SLM instances associated with the X25ELM are configured in a remote location; the instances they consumed on the DT-6160 may be used by another application. However, it should be noted that the X25ELM application is limited to instance numbers one through ten inclusive. As such, the released IP-SLM instance may not be reused for another X25ELM. It should be noted that the default configuration in the preceding table makes maximum utilization of the DT-6160.

The BX.25 line parameters are configured (if needed) on the IP-SLM instance. For most applications; the IP-SLM instance does not require configuration.

Please see the application note in this document for an example deployment.

5. APPLICATIONS COMMANDS

The DT-6xxx software is composed of two components. One component, called the **Platform**, exists to support all applications. The second component is comprised of the individual **application(s)**.

The **Platform** provides Operating System functions, selected interfaces, protocol stacks, SNMP functions, and system OA&M while each **application** uses the services of the resident **Platform**.

5.1 INPUT CONVENTIONS

All parameters may be given on the command line. Parameters of the form **name=<value>** may be given in any order.

For several complex commands, listed below, missing parameters, or corrections of errors in given parameters, of the form **name=<value>** are collected by prompting the console user. The user responds to a prompt for the **name** by typing the required **<value>** followed by *newline*. Defaults are supplied in some cases, so the user need only enter *newline*.

- Commands may be entered in upper or lower case.
- Parameters of the form **name=value** may use upper or lower case for **name**.
- Default values, if any, are shown in parenthesis as part of the prompt.
- Case is preserved for values.
- When a password is being requested by a prompt, input is not echoed.
- Backspace erases one character and @ deletes the current line of input. Most commands are killed by **del** key.

5.2 LOGIN

Syntax: login PASSWD=<password> (*The default password is "initial"*)

The **login** command is used to allow access to the other configuration commands.

The **PASSWD** parameter is not echo suppressed. However, if the **PASSWD** parameter is not provided, the console prompts for a password; the response *is* an asterisk echo in this case.

If the password is valid, the user is placed in the *logged in* mode. Once the console user is logged *in*, the balance of the commands are accessible.

Note: Each application instance is allowed to be assigned a different password.

5.3 LOGOUT

Syntax: logout

The **logout** command is only allowed if the console user is logged *in*. It requires no arguments. It will set the console to the logged *out* mode.

Passwords are up to seven characters in length. The characters are alphanumeric and special characters are not allowed.

5.4 CHANGE PASSWORD

Syntax: chgpas PASSWD=<old> NEWPASS=<new> CONFIRM=<new>

The chgpas command is used to change a user password on the system console. The command is only allowed if the user is logged *in*.

All three parameters must be given on the same line as the command. None of those entries are echo-suppressed.

If the current password is valid, and the two entries for the new password match, the password is changed to the new value.

5.5 HELP

Syntax: help [Command]

The **help** command is always visible. The **help** command displays the currently allowed commands for the mode that the unit is currently entered. If the optional [**Command**] is provided, the displayed help will be limited to that command.

5.6 VERSION

Syntax: ver

The **version** command is only visible when the application is *logged in*. The command has no arguments. It displays the current build, software version, and database version of the **X25ELM** application.

5.7 PLACING COMPONENTS IN SERVICE

Syntax: rs <slm <Link#>> | <vc <VC#>>

The **restore** command is only visible when the application is *logged in*. The command is used to place the BX.25 Link, or any of the X.25 virtual circuits, into service. A TCP connection is not available until the component is placed into service.

At least one argument is required. That argument is the component type to be placed into service. There may be up to two BX.25 links, and multiple X.25 virtual circuits on the aggregate link which may be individually brought into service.

Once the component is brought into service, it will await a TCP session if the connection type is **rcv**. If the connection type is **orig**, a TCP session will be established with the endpoint specified in the component configuration. Connections to the IP-SLM are type **orig**; and connections from

the Operations system are of type rcv. Please see the sections that follow for configuration of both the link, and the virtual circuits.

5.8 TAKING COMPONENTS OUT OF SERVICE

Syntax: rm <slm <link#>> | <vc <vc#>>

The **remove** command is only visible when the application is *logged in*. The command is used to place a BX.25 Link, or any of the BX.25 virtual circuits, out of service. Any TCP connection using those components is automatically taken down when the component is removed from service.

At least one argument is required. That argument is the component type to be removed from service. There are up to two BX.25 links, and multiple X.25 virtual circuits on the link aggregate which may be individually removed from service.

5.9 CONFIGURING GENERAL & SLM PARAMETERS

Syntax: slm <Link#> [dest=<IP Address>] [dport=<TCP Port>]

The **slm** command is only visible when the application is logged in. The command is used to configure each connection to the respective IP-SLM application. Connections to the IP-SLM originate the connection. The IP address would be specified by the **dest** parameter, and the TCP port at that IP address would be specified by the **dport** parameter.

5.10 VIRTUAL CIRCUIT CONFIGURATION

```
Syntax: vc <vc#> [ vcsvc=< PAD | MAC | RBP > ]
           [ padecho=< ON | OFF > ]
           [ paderase=< NONE | BS | <HEX BYTE> ]
           [ padidle=< #X.3 Ticks > ]
           [ padparity=< TRANS | EVEN | ODD > ]
           [ padcrf=< NONE | RMT | VC | BOTH > ]
           [ padfwd=< NONE | CR | CRDROP |
               SEMI | ALL | GRPx > ]
           [ padcmap=< ON | OFF > ]
           [ padapi=< TELNET | RAW > ]
           [ padcug=[+|-]<CUG Number>]
```

The **VC** command is only visible when the application is logged in. The command is used to configure a virtual circuit connection to a Virtual X.25 line.

The **<VC#>** parameter refers to the virtual circuit configured on the aggregate BX.25 line. It has the range of 1 through 7 inclusive.

The **vcsvc=< PAD | RBP | MAC >** option determines the type of service for a virtual circuit. The VC must have been specified on the command line. When set to the value of **PAD**, the virtual circuit is terminated in an X.3 PAD. When a value of **MAC** is selected, a special interface for the MacStar operation system is used. When a value of **RBP** is selected, the *Record Boundary Preservation* protocol is selected. Other interfaces can be included, see the last section of this document for contact information.

The **padecho=< ON | OFF >** refers to reference #2 in the X.3 parameter list. When set to **OFF**, the PAD will not echo characters back to the IP endpoint. When set to the value of **ON**, all characters are to be echoed back to the IP source.

The **paderase=< NONE | BS | <HEX BYTE> >** option specifies reference #16 in the X.3 parameter list. It is used with manual telnet connections to an X.25 VC. It sets the buffer editing "erase" character. When the special "erase" character is received by the X25ELM for a specific virtual circuit, the previous character in the packet accumulation buffer is deleted. If the **padecho** option was also enabled, a "Backspace Blank Backspace" sequence is emitted to the user. When the **paderase** option is set to **NONE**, the PAD will not have a special "erase" character. When the value is **BS**, it is set to the ASCII backspace character 0x08. Otherwise, any character may be entered as a hexadecimal byte in 0xXX notation. This option is only valid on X.25 virtual circuits configured with the PAD interface.

The **padidle=<#X.3 ticks>** parameter refers to reference #4 of the X.3 parameter list. This is the time forwarding condition. When it expires, it will forward any data collected to the X.25 circuit.

The timer is reset to the specified timer value whenever a forwarding condition is reached. The value is based on ticks of 1/20th of a second each per the X.3 specification.

The **padparity=< TRANS | EVEN | ODD >** parameter is not present in the X.3 parameter list. It allows special parity treatment for interface to network elements that require parity. The default value is transparent operation. The value of **TRANS** sets the operation to be transparent. When the parity treatment is transparent, the data is not modified in either direction. The value of **EVEN** sets the operation to be even parity towards the (B)X.25 device, and stripped parity towards the TELNET. The value of **ODD** sets the operation to be odd parity towards the (B)X.25 device, and stripped parity towards the TELNET.

The **padcrif=<NONE | RMT | VC | BOTH>** parameter refers to reference #13 of the X.3 parameter list. This is the action to be taken when a CR is received in the data stream from the remote IP endpoint. A value of **NONE** indicates that there is to be no LF (line feed) insertion. A value of **RMT** will insert an LF following a CR whenever it is sent towards the remote IP endpoint. A value of **VC** will insert an LF following a CR whenever it is sent towards the X.25 virtual circuit. A value of **BOTH** will insert an LF following a CR in either direction.

The **padfwd=<NONE | CR | CRDROP | SEMI | ALL | GRPx>** option specifies reference #3 of the X.3 parameter list. This is the forwarding condition (outside the PAD timer) which will forward data towards the X.25 virtual circuit. A value of **NONE** indicates that there are no character forwarding conditions. A value of **CR** indicates that a carriage return will forward any accumulated data (including the carriage return). A value of **CRDROP** indicates that a carriage return will forward any accumulated data (but not including the carriage return). A value of **SEMI** indicates that a semicolon will forward any accumulated data including the semicolon. A value of **ALL** indicates that all data is to be forwarded immediately. The **ALL** option has the effect of generating single user character X.25 packets on this virtual circuit. The **GRPx** values specify selected groups of forwarding characters. **GRP1** forwards on ESC, BEL, ENQ, and NAK. **GRP2** forwards on DEL, CAN, DC2. **GRP3** forwards on ETX, EOT. **GRP4** forwards on HT, LF, VT, and FF. Multiple forwarding conditions are allowed simultaneously. Setting **padfwd** to a value aggregates with the previous value of **padfwd**. The **padfwd=none** is required to clear the forwarding conditions.

The **padcmap=< ON | OFF >** option provides the automatic case mapping from lower case to upper case. When the option is set to **ON**, all lower case characters are automatically converted to upper case. When **OFF**, no transformations are performed.

The **padapi=< TELNET | RAW >** option provides a means of selecting the PAD virtual circuit to use **raw** protocol. The **raw** protocol is essentially asynchronous, but without the benefit of Telnet RFC encapsulation. It is used for applications that do not implement the Telnet RFC. The default for this option is to use the Telnet encapsulation.

The **padcug=[+]-<CUG Number>** parameter allows the virtual circuit connection to be protected by closed user group membership. The closed user group feature is significant only for PAD service. The closed user group address entries are defined with the **cug** command. Any or all closed user group entries may be assigned with a virtual circuit.

5.11 DISPLAY MEASUREMENTS

Syntax: `dmeas <slm <Link#>> | <vc <VC#> > | ALL>`

The **dmeas** command is only visible when the application is logged in. The command is used to display the current measurements on either the X.25 link or per virtual circuit.

The **SLM <Link#>** parameter will display the measurement information for the X.25 link being supported by this instance of the application.

The **VC <VC#>** option will display the measurement information for a particular X.25 virtual circuit on the link. The virtual circuit number is in the range of one through the maximum number supported by the application.

5.12 VERIFY CONFIGURATION

Syntax: `vfy [all | app | slm | cug | vc <VC#>]`

The **vfy** command is only visible when the application is logged in. The command is used to display the configured options on the X.25 link, or a virtual circuit resident on the X.25 link.

The **SLM** parameter will display the configuration information for the X.25 SLM links being supported by this instance of the application.

The **VC <VC#>** parameter will display the configuration information for a particular X.25 virtual circuit on the link. The virtual circuit number is in the range of 1 through seven, the maximum number supported by the application.

The **APP** parameter will display information about the application instance. This includes user comments, and the instance identifier.

The **CUG** parameter will display information about the configuration of the closed user groups.

5.13 DISPLAYING CURRENT CONNECTIONS

Syntax: `dc`

The **dc** command is used to display all of the current connections into the X25ELM application. This includes the IP-SLM link, and any X.25 virtual circuit connections. The command will issue a report that shows the connection peer for each active connection.

5.14 SNOOPING TRAFFIC

Syntax: `snoop [OFF | SLM | ALL | <VC# Range>] [verbose]`

The application has a diagnostic ability to snoop on either link at the SLM layer, or on an individual circuit at the packet layer. This is done with the **snoop** command. All output is directed to the OA&M connection.

If the command is invoked with no arguments, it produces a report of all active snooper configurations.

If the command is invoked with the **OFF** option, all of the snooper configurations are disabled.

If the command is invoked with the **SLM** option, the SLM link interface to the IP-SLM application is snooped. Output is displayed on the OA&M session. Please note that this could be extensive for a moderately busy BX.25 line.

If the command is invoked with the **ALL** option, the **SLM** interface and all of the virtual circuits that have been configured have snooping enabled.

If the command is invoked with a virtual circuit number in the range of 1 through seven, the maximum number of BX.25 circuits in a NE connection; the packet generation of data is snooped. The virtual circuits may be specified in a range (e.g. 1-5).

The additional parameter of **[verbose]** will display all of the data bytes in addition to the standard decoding. The output of this option may become quite voluminous.

5.15 PROMPT LABELS

Syntax: label ["Any Label" | NONE]

The prompt on the application console may be customized with a label up to sixty characters in length. Spaces and special characters are allowed within the double quotes. The double quotes are required on this command. The value of **none** deletes any existing label on the prompt. The current configuration is displayed during a *verify configuration*, by invoking the **label** command without arguments, or merely by the prompt display.

5.16 APPLICATION COMMENTS

**Syntax: comment [L1="Any Comment"
[L2="Any Comment"
[L3="Any Comment"**

The application may have comments which are displayed with the *verify configuration* command. Up to three lines of comments are available. Each line may have a comment up to 64 characters in length. Each comment is double quoted to allow for spaces to be embedded. A comment with no characters (i.e. "") is used to delete a comment which is not desired. It is not necessary to delete prior to adding a new comment. The new comment shall replace the existing comment at the line specified.

5.17 CLOSED USER GROUPS

Syntax: cug <CUG Number> [ipaddr=<IP Address>] [submask=<IP Mask>]

The **CUG** command allows the definition of address sets to create multiple closed user groups. The address sets are then used by the link, console, and virtual circuits in creating individual closed user groups. The **<CUG Number>** has a range of one through sixteen.

5.18 CONSOLE SECURITY

Syntax: console [cug=[+|-]<CUG Number>]

The **CONSOLE** command allows the assignment of a closed user group to the administration session. The closed user group must include the current administrator to prevent accidental lockout. This restriction is enforced.

6. X25ELM MEASUREMENTS AVAILABLE

This appendix itemizes the measurements available using the *display measurements (dmeas)* command. There are two options to the **dmeas** command. These are **slm** and **vc**.

The **slm** option provides X.25 Link level measurements, and the **vc** option provides per virtual circuit measurements.

The base measurements are always displayed, and the error and exception counters are only displayed if nonzero.

The link level measurements available are as follows:

Measurement Description	Type
Number of SLM Frames Received	Base
Number of SLM Frames Transmitted	Base
Number of SLM Bytes Received	Base
Number of SLM Bytes Transmitted	Base

The per virtual circuit measurements available are as follows:

Measurement Description	Type
Number of SLM Packets Received from IP-SLM	Base
Number of SLM Packets Sent to IP-SLM	Base
Number of Bytes Received from the BX.25 Link via IP-SLM	Base
Number of Bytes Sent to BX.25 Link via IP-SLM	Base

7. SUPPORT FOR X.3 PAD PARAMETER VALUES

The X25ELM supports the relevant X.3 PAD parameters. Since the X25ELM is not a physical device, some of the parameters are not readily applicable. Responses via X.29 will carry default values if queried.

The table below will indicate all the X.3 parameters, and the support of these parameters by the X25ELM application.

Ref #	Description	Supported Options	Note	Config
1	PAD recall	0 – None	User Command session provided by Datakit CC or DT-4000 or DT-2020.	No
2	Echo	0 – No Echo 1 – Echo		Yes
3	Data Forwarding Characters	0 – None 2 – CR 126 – All Characters		Yes
4	Idle Delay	0-255	Ticks are in 1/20 th of a second.	Yes
5	Ancillary Device Control	0 – None	Configured on DT-4000 or SAM/DT-2020 port configuration	No
6	Control of PAD service signals and PAD command signals.	0 – No PAD service signals are transmitted.	DT-4000 or SAM is DTE service center.	No
7	Operation of PAD on receipt of break from IP	0 – Nothing 1 – Send X.25 Interrupt 2 – Send X.25 Reset 4 – X.29 “Indication of Break”		Yes
8	Discard Output	0 – Normal Data Delivery		No
9	Padding after CR	0 – No Padding after CR		No
10	Line Folding	0 – No line folding		No
11	Binary Speed	18 – 64000bps	For Reporting Only	No
12	Flow Control of the PAD	0 – No use of X-ON and X-OFF	These are functions of the DT-4000 and SAM devices.	No

13	LineFeed Insertion after CR	0 – No Linefeed Insertion 1 – Insert Linefeed after CR towards IP. 2 – Insert Linefeed after CR from IP		Yes
14	Padding after Linefeed	0 – No Padding after LF		No
15	Editing	0 – No use of editing.	User command session performed via the DK CC, the DT-4000, and the DT-2020.	No
16	Character Delete	None	User command session performed via the DK CC, the DT-4000, and the DT-2020.	No
17	Line Delete	None	User command session performed via the DK CC, the DT-4000, and the DT-2020.	No
18	Line Display	None	User command session performed via the DK CC, the DT-4000, and the DT-2020.	No
19	Editing PAD service signals	0 - None		No
20	Echo Mask	0 - None		No
21	Parity	0 – No generation or checking.	Parity performed by DT-4000 or SAM.	No
22	Page Wait	0 - Disabled		No
23	Input field size	0 - Undefined	User command session performed via the DK CC, the DT-4000, and the DT-2020.	No
24	End of Frame Signals	0 – Undefined Size	EOF is determined and encoded per the RFC since this is an IP application.	No
25	Extended Data Forwarding Signals	0 – No extended Data		No
26	Display Interrupt	0 – No display interrupt		No
27	Display Interrupt Confirmation	0 – No display interrupt confirmation.		No
28	Diacritic Character Coding	0 – Basic Coding		No

DT-6xxx X25ELM Application User's Manual

29	Extended Echo Mask	0 – No Extended Echo Mask		No
----	--------------------	---------------------------	--	----

8. X25ELM SAMPLE DEPLOYMENT

This section presents the configuration of all components needed for a deployment. Consider the following diagram from the introduction.

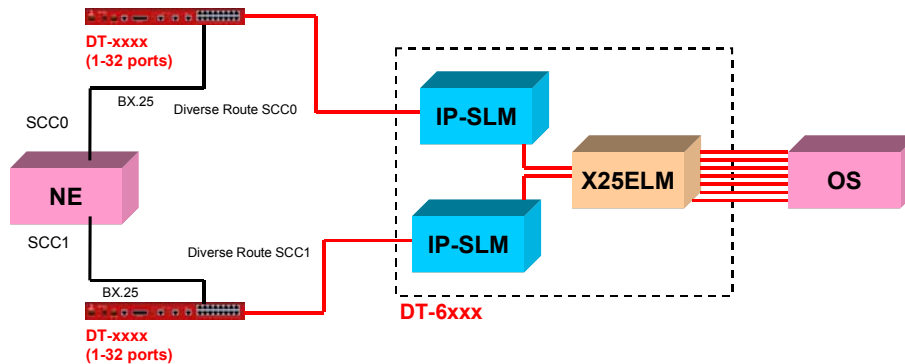

Note: IP Network not shown for clarity.
Red lines are TCP/IP.

For the purposes of this section,

- The IP address of the DT-6xxx is 192.168.0.222
- The IP address of the DT-xxxx at SCC0 is 192.168.0.51.
- The IP address of the DT-xxxx at SCC1 is 192.168.0.52.
- Port #1 on each DT-xxxx is used to connect to the NE.
- The IP address of the OS is not relevant for this configuration.
- The Instance number used for X25ELM is one (1).
- The Instance number used for IP-SLM for SCC0 is eleven (11).
- The Instance number used for IP-SLM for SCC1 is twenty one (21).

At the DT-6xxx infrastructure console, either serial or telnet, set the instances to the respective application. The DT-6xxx infrastructure console is accessed via the unix (or Windows Cygwin) command:

```
telnet 192.168.0.222 1023
login passwd=initial
app 11 cnt=20 type=ip_slm
app 1 cnt=10 type=x25elm
```

The DT-6xxx infrastructure console is no longer required and may be disconnected.

The X25ELM console is accessed via the unix (or Windows Cygwin) command:

```
telnet 192.168.0.222 10001
```

Log into the X25ELM with the command "login passwd=initial".

The X25ELM is automatically configured for the default configuration where the SCC0 IP-SLM is at instance (10 + <X25ELM instance>), and the SCC1 IP-SLM resides at instance (20 + <X25ELM instance>). Both on the same DT-6xxx redundant cluster.

The X25ELM is automatically configured for the default configuration where each VC is using the PAD interface, with Telnet protocol encoding, automatic upper case conversion, and semicolon forwarding. This is typical for TL1.

The DT-xxxx for SCC0 has its console at TCP 1023. The SCC0 DT-xxxx infrastructure console is accessed via the unix (or Windows Cygwin) command:

```
telnet 192.168.0.51 1023
```

Configure the port as follows:

```
rm p 1
port 1 type=orig prot=sdhc dxe=dce baud=9600
port 1 dest=192.168.0.222 dport=32000 pap=on
rs p 1
```

The above will connect the SCC0 DT-xxxx port to the IP-SLM for SCC0 executing as instance 11 on the DT-6xxx redundant cluster.

The connection may be checked with the display connections command ("dc"). The SCC0 DT-xxxx console is no longer required and may be disconnected.

The DT-xxxx for SCC1 has its console at TCP 1023. The SCC1 DT-xxxx infrastructure console is accessed via the unix (or Windows Cygwin) command:

```
telnet 192.168.0.52 1023
```

Configure the port as follows:

```
rm p 1
port 1 type=orig prot=sdhc dxe=dce baud=9600
port 1 dest=192.168.0.222 dport=34000 pap=on
rs p 1
```

The above will connect the SCC1 DT-xxxx port to the IP-SLM for SCC1 executing as instance 21 on the DT-6xxx redundant cluster.

The connection may be checked with the display connections command ("dc"). The SCC1 DT-xxxx console is no longer required and may be disconnected.

Assuming that the NE has at least one link available, the NE aggregate connection is now accessible via telnet as follows:

```
telnet 192.168.0.222 30001 for VC #1.  
through  
telnet 192.168.0.222 30007 for VC #7.
```

Other encodings are supported. Many Operations Systems use packet oriented interfaces such as the MACSTAR or RBP interfaces. Please contact the author for relevant details.

9. END-USER LICENSE AGREEMENT FOR SOFTWARE

This License Agreement ("License") is a legal contract between you and the manufacturer ("Manufacturer") of the system ("HARDWARE") with which you acquired software product(s) identified above ("SOFTWARE"). The SOFTWARE may include printed materials that accompany the SOFTWARE. Any software provided along with the SOFTWARE that is associated with a separate end-user license agreement is licensed to you under the terms of that license agreement. By installing, copying, downloading, accessing or otherwise using the SOFTWARE, you agree to be bound by the terms of this LICENSE. If you do not agree to the terms of this LICENSE, Manufacturer is unwilling to license the SOFTWARE to you. In such event, you may not use or copy the SOFTWARE, and you should promptly contact Manufacturer for instructions on return of the unused product(s) for a refund.

SOFTWARE LICENSE

You may only install and use one copy of the SOFTWARE on the HARDWARE (unless otherwise licensed by Manufacturer). The SOFTWARE may not be installed, accessed, displayed, run, shared or used concurrently on or from different computers, including a workstation, terminal or other digital electronic device ("Devices"). Notwithstanding the foregoing and except as otherwise provided below, any number of Devices may access or otherwise utilize the services of the SOFTWARE. You may not reverse engineer, decompile, or disassemble the SOFTWARE, except and only to the extent that such activity is expressly permitted by applicable law notwithstanding this limitation. The SOFTWARE is licensed as a single product. Its component parts may not be separated for use on more than one HARDWARE. The SOFTWARE is licensed with the HARDWARE as a single integrated product. The SOFTWARE may only be used with the HARDWARE as set forth in this LICENSE. You may not rent, lease or lend the SOFTWARE in any manner. You may permanently transfer all of your rights under this LICENSE only as part of a permanent sale or transfer of the HARDWARE, provided you retain no copies, you transfer all of the SOFTWARE (including all component parts, the media and printed materials, any upgrades, this LICENSE and, if applicable, the Certificate(s) of Authenticity), and the recipient agrees to the terms of this LICENSE. If the SOFTWARE is an upgrade, any transfer must also include all prior versions of the SOFTWARE. Without prejudice to any other rights, Manufacturer may terminate this LICENSE if you fail to comply with the terms and conditions of this LICENSE. In such event, you must destroy all copies of the SOFTWARE and all of its component parts.

INTELLECTUAL PROPERTY RIGHTS

The SOFTWARE is licensed, not sold to you. The SOFTWARE is protected by copyright laws and international copyright treaties, as well as other intellectual property laws and treaties. You may not copy the printed materials accompanying the SOFTWARE. All title and intellectual property rights in and to the content which may be accessed through use of the SOFTWARE is the property of the respective content owner and may be protected by applicable copyright or other intellectual property laws and treaties. This LICENSE grants you no rights to use such content. All rights not expressly granted under this LICENSE are reserved Manufacturer and its licensors (if any).

SOFTWARE SUPPORT

SOFTWARE support is not provided by Manufacturer, or its affiliates or subsidiaries separate from the HARDWARE. For SOFTWARE support, please contact your supplier of the HARDWARE. Should you have any questions concerning this LICENSE, or if you desire to contact Manufacturer for any other reason, please refer to the address provided in the documentation for the HARDWARE.

EXPORT RESTRICTIONS

You agree that you will not export or re-export the SOFTWARE to any country, person, or entity subject to U.S. export restrictions. You specifically agree not to export or re-export the SOFTWARE: (i) to any country to which the U.S. has embargoed or restricted the export of goods or services, which as of March 1998 include, but are not necessarily limited to Cuba, Iran, Iraq, Libya, North Korea, Sudan and Syria, or to any national of any such country, wherever located, who intends to transmit or transport the products back to such country; (ii) to any person or entity who you know or have reason to know will utilize the SOFTWARE or portion thereof in the design, development or production of nuclear, chemical or biological weapons; or (iii) to any person or entity who has been prohibited from participating in U.S. export transactions by any federal agency of the U.S. government.

LIMITED WARRANTY

Manufacturer warrants that (a) the SOFTWARE will perform substantially in accordance with the accompanying written materials for a period of ninety (90) days from the date of shipment from TeleComp R&D or a designated manufacturer. Software support is limited to the hours of 9AM to 5PM ET Monday through Friday excluding TeleComp R&D observed holidays. An extended warranty may be purchased at additional cost. Any implied warranties on the SOFTWARE are

limited to ninety (90) days. Some states/jurisdictions do not allow limitations on duration of an implied warranty, so the above limitation may not apply to you.

Manufacturer's and its suppliers' entire liability and your exclusive remedy shall be, at Manufacturer's option, either (a) return of the price paid, or (b) repair or replacement of the SOFTWARE that does not meet this Limited Warranty and which is returned to Manufacturer with a copy of your receipt. This Limited Warranty is void if failure of the SOFTWARE has resulted from accident, abuse, or misapplication. Any replacement SOFTWARE will be warranted for the remainder of the original warranty period or thirty (30) days, whichever is longer.

NO OTHER WARRANTIES

TO THE MAXIMUM EXTENT PERMITTED BY APPLICABLE LAW, MANUFACTURER AND ITS SUPPLIERS DISCLAIM ALL OTHER WARRANTIES, EITHER EXPRESS OR IMPLIED, INCLUDING, BUT NOT LIMITED TO IMPLIED WARRANTIES OF MERCHANTABILITY, FITNESS FOR A PARTICULAR PURPOSE AND NONINFRINGEMENT, WITH REGARD TO THE SOFTWARE AND THE ACCOMPANYING WRITTEN MATERIALS. THIS LIMITED WARRANTY GIVES YOU SPECIFIC LEGAL RIGHTS. YOU MAY HAVE OTHERS, WHICH VARY FROM STATE/JURISDICTION TO STATE/JURISDICTION.

LIMITATION OF LIABILITY

To the maximum extent permitted by applicable law, in no event shall Manufacturer or its suppliers be liable for any damages whatsoever (including without limitation, special, incidental, consequential, or indirect damages for personal injury, loss of business profits, business interruption, loss of business information, or any other pecuniary loss) arising out of the use of or inability to use this product, even if Manufacturer has been advised of the possibility of such damages. In any case, Manufacturer's and its suppliers' entire liability under any provision of this License shall be limited to the amount actually paid by you for the SOFTWARE and/or the HARDWARE. Because some states/jurisdictions do not allow the exclusion or limitation of liability for consequential or incidental damages, the above limitation may not apply to you.

SPECIAL PROVISIONS

The SOFTWARE and documentation are provided with RESTRICTED RIGHTS. Use, duplication, or disclosure by the United States Government is subject to restrictions as set forth in subparagraph (c)(1)(ii) of the Rights in Technical Data and HARDWARE Software clause at DFARS 252.227-7013 or subparagraphs (c)(1) and (2) of the Commercial HARDWARE Software-Restricted Rights at 48 CFR 52.227-19, as applicable. Manufacturer is TeleComp R&D or it's designee manufacturer., 102 SW Orange Blossom, Lake City, Florida, 32025.

If you acquired the SOFTWARE in the United States of America, this Software License are governed by the laws of the State of Florida, excluding its choice of laws provisions. If you acquired the SOFTWARE outside the United States of America, local law may apply. This LICENSE constitutes the entire understanding and agreement between you and the Manufacturer in relation to the SOFTWARE and supercedes any and all prior or other communications, statements, documents, agreements or other information between the parties with respect to the subject matter hereof.

10. SALES & DISTRIBUTION



Communications Technology Solutions

CBM of America, Inc.
Mr. Mike Stephens
1455 West Newport Center Drive
Deerfield Beach, Florida
33442

800-881-8202
954-698-9104 Fax: 954-360-0682

www.cbmusa.com



Datatek Applications, Inc.

Mr. Dan Conklin
379 Campus Drive, Suite 100
Somerset, New Jersey
08873

732-667-1080 Fax: 732-667-1091

www.datatekcorp.com

11. AUTHOR

Comments and Questions regarding this document or the products covered within this document should be addressed to the author Angel Gomez via email at angel@trdcusa.com or via telephone at 386-754-5700.

©Copyright 2002, 2008 TeleComp Research & Development Corp.

©Copyright 1998, 2002 TeleComp Inc.

All Rights Reserved

Printed in USA

Datakit® and StarKeeper® II NMS are registered trademarks of Lucent Technologies.